

**Radio receiver module VNBFP490
with master radio key**

Installation, operation and maintenance instructions



These instructions are to be passed on by the fitter to the user.



Content

1	Application	3
2	Delivery Scope.....	3
3	Positioning.....	3
4	Installation dimensions.....	4
5	Installation and component description	5
6	Master radio key	6
7	Programming button	6
8	User key.....	7
8.1	Tuning in new user keys	7
8.2	Deleting individual user keys	8
8.3	Deleting all user keys	9
9	Technical Data	10
9.1	Radio receiver	10
9.2	Master radio key	10
10	The radio receiver's LED signals	10
11	Safety instructions, maintenance and care	11
11.1	Changing the radio key battery	11

1 Application

The radio receiver module VNBFP490 is a rolling-code radio receiver for opening FUHR **multitronic** 881 and **autotronic** 834/836(P) motorised lock systems, by means of up to max. 25 different radio transmitters.

The radio receiver is compatible with all conventional FUHR transmitter modules, e.g.: radio key, radio fingerprint scanner, radio transponder reader, radio keypad.



Radio key
VNZ80317/ VNZ80319



Fingerprint scanner
VNB870N



Transponder
VNB693N



Keypad
VNB702N

2 Delivery scope

Radio receiver with connection cable

Master radio key, 4 channels



3 Positioning

The radio receiver is plugged in behind the lock faceplate at the top end of the motor drive unit and connected to the green motor plug with the enclosed 3-core connection cable.

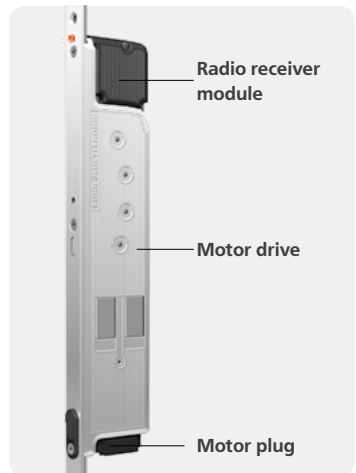

4 Installation dimensions

The module fits into the 280 mm long drive unit's standard routing.

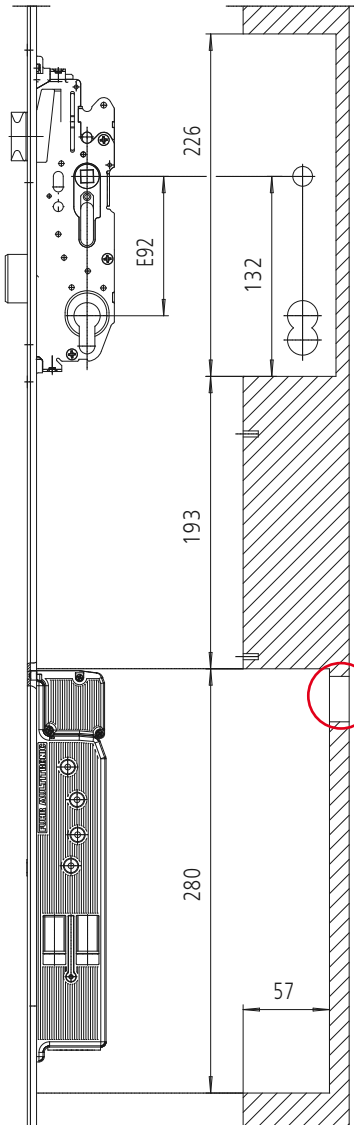

Tip: On metal door leaves, the reception range can be increased by notching out the profile wall towards the glazing rebate area behind the radio receiver module.

5 Installation and component description

The VNBFP490 radio receiver module (1) has a transparent programming button with a red indicator LED (2) for programming the FUHR radio transmitters as well as a 3-wire connection cable (3) which is connected to the green plug of the motor drive.

For positioning and fixing to the motor drive, the housing of the radio module is equipped with an insertion channel (4) and a catch spring (5). The motor drive has corresponding mounting areas* (6). The radio receiver module is pushed downwards along the insertion channel until the catch spring engages positively in the motor drive housing.

There is an opening* (7) in the lock faceplate above the motor through which the LED programming button (2) can be operated from the outside with a thin object when installed.

For disassembly, this LED programming button must first be pressed before the radio receiver module can be pulled upwards.

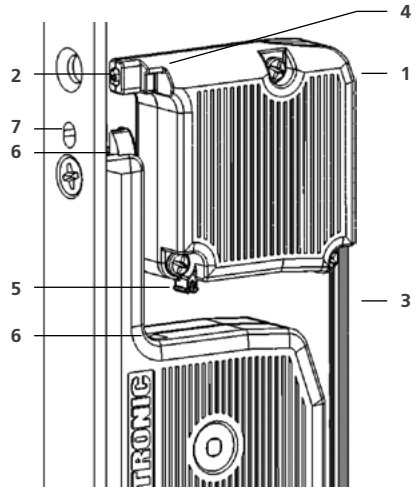

*from date of manufacture: 04/2010

Three cables are located on the back of the radio receiver: white, brown & green. Please connect these three cables in the correct order to the following screw terminals of the motor plug:

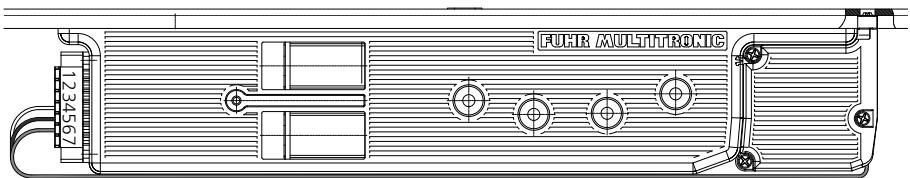

Terminal 4 – white cable
Terminal 5 – brown cable
Terminal 6 – green cable

After the 12 V DC power supply of the motor lock (terminal 2-3 refer to installation instructions **multitronic** 881/**autotronic** 834/836 – www.fuhr.de) has been connected, the radio receiver is ready for use.

6 Master radio key

The radio receiver distinguishes between **master keys** and **user keys**.



The **master key** is always unique! It cannot be deleted, replaced or modified. More user keys can be tuned in to the radio receiver with it, or alternatively user keys can also be deleted. **The master key is unique and must not be lost under any circumstances!** It is also suitable for opening the door.

Your radio receiver is supplied with a factory-set master key. You recognise the master key by the **red** buttons.

The front, middle button is the tuned-in master button. The other three buttons are still free transmission buttons. (e.g. for garage door drives, etc.).

You can immediately use the master key to emit a radio signal to open the door. The LED programming button lights up for 2 seconds when the valid signal is detected.

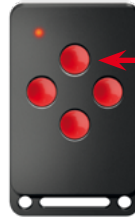

Master button
(factory-set)

7 Programming button

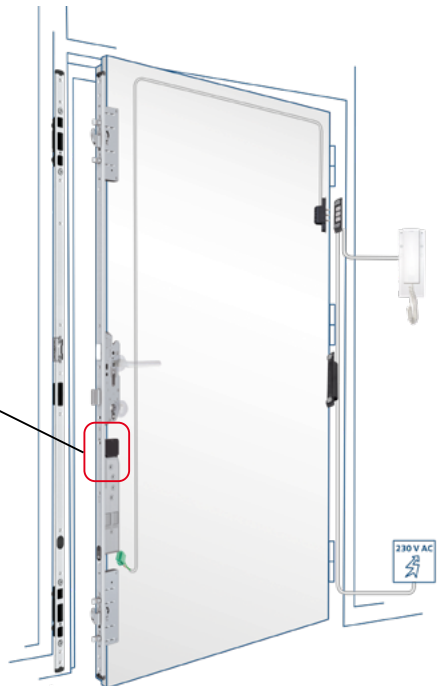
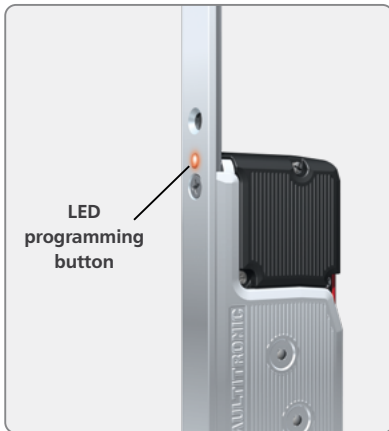

8 User key

Apart from the previously tuned in master key, **up to 24 user keys** can be tuned in to the radio receiver. The user keys serve only to open the door; they have no tuning in or deleting authorisation.

All FUHR radio transmitters are suitable as user transmitters, e.g.: radio key, radio fingerprint scanner, radio transponder, radio keypad.



For safety reasons, we recommend to delete all radio keys first during initial start-up (see chapter 8.3). Then proceed as follows:

8.1 Tuning in new user keys



1. Activate the radio receiver's LED programming button **briefly (<1 second)** with a thin object.

» The red LED flashes slowly.

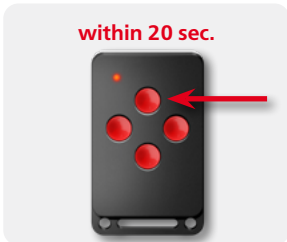

2. Now press the front centre button of the master key **within 20 seconds**.

» If the radio receiver module has accepted the master key, the LED lights up for 2 seconds and then continues to flash slowly.

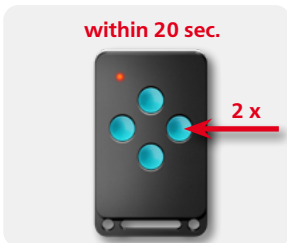

3. **Within 20 seconds**, press a button of the radio key to be learned **twice** in succession. If the time limit of 20 seconds is exceeded, the learning process is aborted.

» If the new radio key has been accepted by the radio receiver module, the red LED lights up for 4 seconds.

4. For tuning in more user keys, start again with step 1.

8.2 Deleting individual user keys

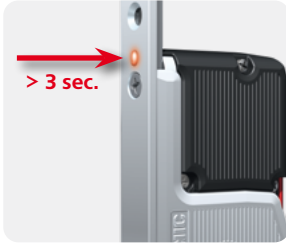

1. Carefully press the programming button of the radio receiver module (**longer than 3 seconds**) until the red LED flashes quickly. Then release the button.

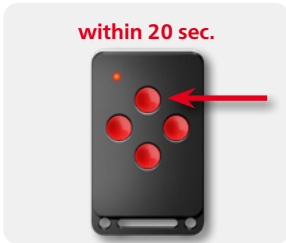

2. Now press the front centre button of the master key **within 20 seconds**.
» If the radio receiver module has accepted the master key, the LED lights up for 2 seconds and then continues to flash quickly.

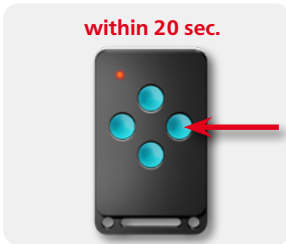

3. **Within 20 seconds**, press the corresponding button of the radio key to be deleted. If the time limit of 20 seconds is exceeded, the deleting process is aborted.
» If the transmitter code was successfully deleted, the red LED lights up for 4 seconds.

4. If you want to delete another radio key, start again with step 1.

8.3 Deleting all user keys

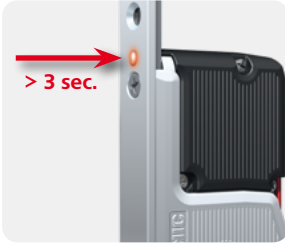

1. Carefully press the programming button of the radio receiver module (**longer than 3 seconds**) until the red LED flashes quickly. Then release the button.

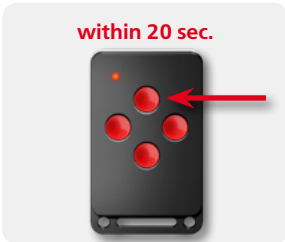

2. Now press the front centre button of the master key **within 20 seconds**.
 - » If the radio receiver module has accepted the master key, the LED lights up for 2 seconds and then continues to flash quickly.



3. **Within 20 seconds**, press the programming button of the radio receiver module again for **longer than 3 seconds**. If the time limit of 20 seconds is exceeded, the deleting process is aborted.
 - » If all transmitter codes (except the master transmitter code) were successfully deleted, the red LED lights up for 4 seconds.

9 Technical data

9.1 Radio receiver

Frequency:	868.3 MHz
Modulation:	FSK (frequency shift keying)
Security:	Rolling-code with master transmission principle
Aerial:	On board
Power supply:	12 V DC
Current consumption:	15 mA
Operating control:	Red light emitting diode (LED)
Temperature range:	-10°C to +50°C
Dimensions:	43 x 40 x 15 mm
Connection cable:	3-core, approx. 320 mm long
Weight:	approx. 50 g
IP rating:	IP 20
Switching impulse:	Potential-free

9.2 Master radio key

The radio transmitters conform to the R&TTE guideline 2014/53/EU

Frequency:	868.3 MHz
Modulation:	FSK (frequency shift keying)
Security:	Rolling-code
Channels:	4
Power supply:	1 x 3 V battery, CR 2032
Operating control:	Red light emitting diode (LED)
Temperature range:	-10°C to +50°C
Dimensions:	61,5 x 37 x 10,5 mm
Weight:	approx. 11 g

10 The radio receiver's LED signals

The following LED signals can only be checked after applying the 12 V DC power supply.

The LED tune in button lights up permanently

- A master key has not been tuned in yet.
Please note: The first radio transmitter tuned in is the future master radio transmitter!

The LED tune in button lights up for 2 seconds

- A previously tuned in transmission signal has been received, the lock unlocks motor-driven.

The LED tune in button lights up for 0.5 seconds

- A transmission signal that has not yet been tuned in has been received, the lock does not unlock.

The LED tune in button doesn't light up at all

- The LED does not light up in the non-actuated home position as no transmission signal has been received. If, however, the LED does not light up despite the transmission of an opening signal, the radio receiver or the motor lock has not yet been connected to the operating voltage of 12 V DC or the cables on the motor plug have been incorrectly connected.

11 Safety instructions, maintenance and care

The radio receiver module is maintenance-free. If the transmission range of the radio key decreases, please replace the battery (refer to chapter 11.1).

The supplied components are to be protected against humidity. They are not suitable for areas with high humidity and chemical substances!

Only original FUHR accessories may be used. We accept no liability for incorrect installation or operation. The housings and cables are to be protected against mechanical damage. Damaged or faulty components must be decommissioned and replaced immediately.

11.1 Changing the radio key battery

The radio keys are particularly power-saving and have a battery indicator light. The battery lasts for about 50,000 operations. Check the battery indicator light regularly to avoid failure. For changing the radio key battery, follow the steps below:

1. Open the radio key's housing carefully with a thin object, e.g. slotted screwdriver.
2. Slide out the battery.
3. Insert the new CR2032 battery, with the plus symbol pointing upwards.
4. Press the radio key's housing together again.

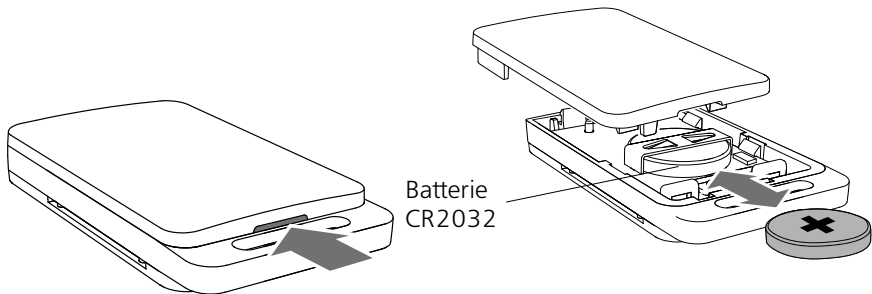



CARL FUHR GmbH & Co. KG

Carl-Fuhr-Straße 12
D-42579 Heiligenhaus
Tel.: +49 2056 592-0
www.fuhr.de · info@fuhr.de